

CP-1 Compressor/Limiter

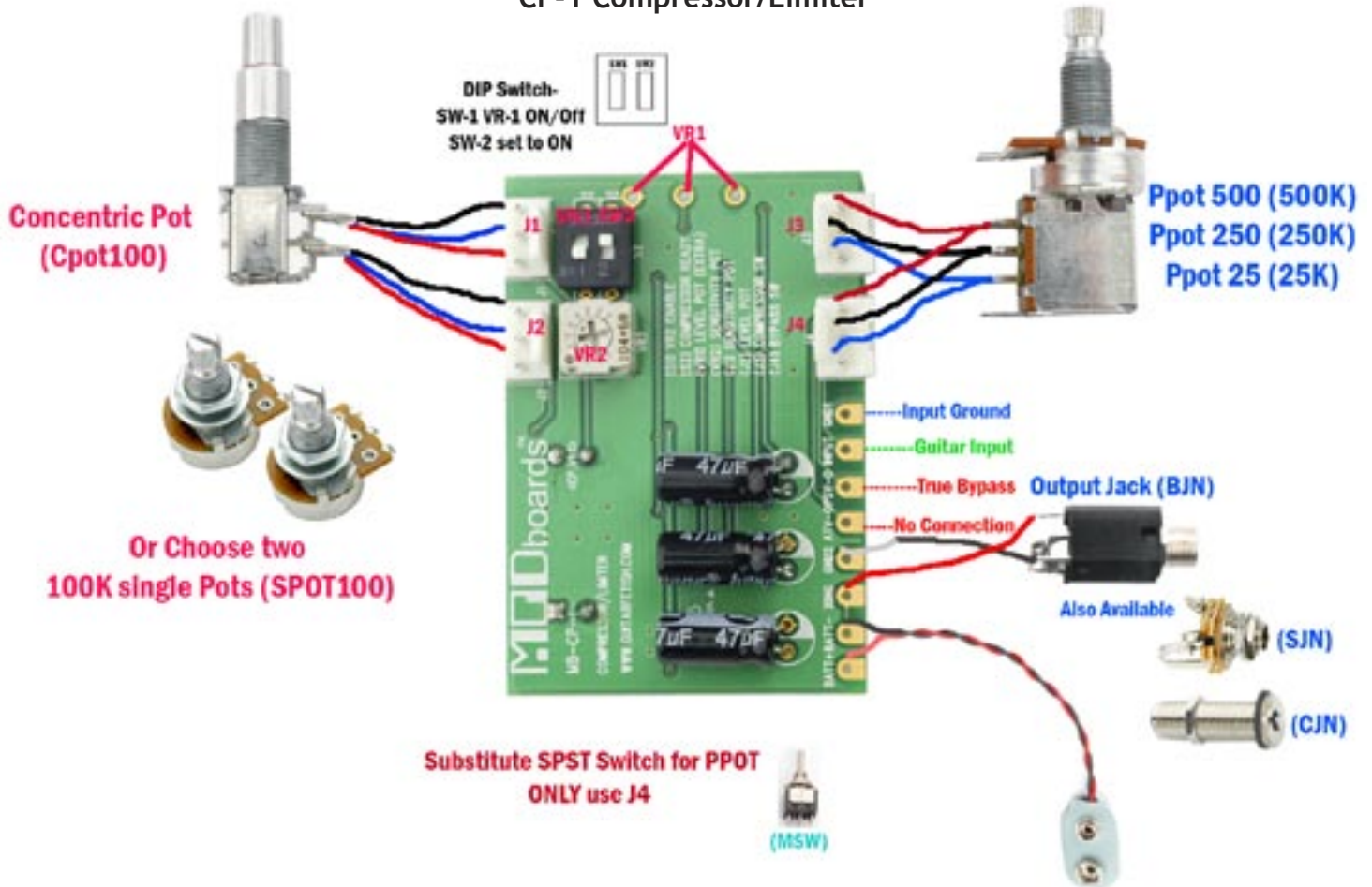

The CP-1 Compressor Limiter is an extremely versatile tool. Whether set to enhance clean picking, increase crispness and jangle, or just for all out sustain, the key to using the CP-1 is mastering its controls. The control setup is similar to a footpedal- VR2 must be pre-set, J1 and J2 are user adjustable.

J1- Threshold- Sets the level at which the circuit is engaged

J2- Gain- Sets the maximum output level of the effected sound

VR2- Speed- Low settings for quick response, high setting for slower response.

You'll find that low settings of VR2 work best for enhancing clean playing, while higher settings allow the effect to build as the note dies, for a natural sustain. Setting J1 fully counterclockwise engages just the limiter with very little compression, cranking it higher dials out some limiter and dials in a lot of compression. The Gain control sets the output level. We find that experimenting with the controls is important to find the sweet spot for your guitar and amp combo.

A nice trick is to set the gain level a little below unity gain, and then to create infinite sustain dial the control up slowly with your pinky as the note begins to die. With a loud amp you'll soon have great sustain that just won't die!

True Bypass- The CP-1 is used in True Bypass mode. In this mode when the switch is off the guitar is 100% PASSIVE- no battery needed. This extends battery life and gives you the true unaffected sound of your guitar. When used with the MSW single switch use J4 only.